

Jiexun – A Hybrid Hero

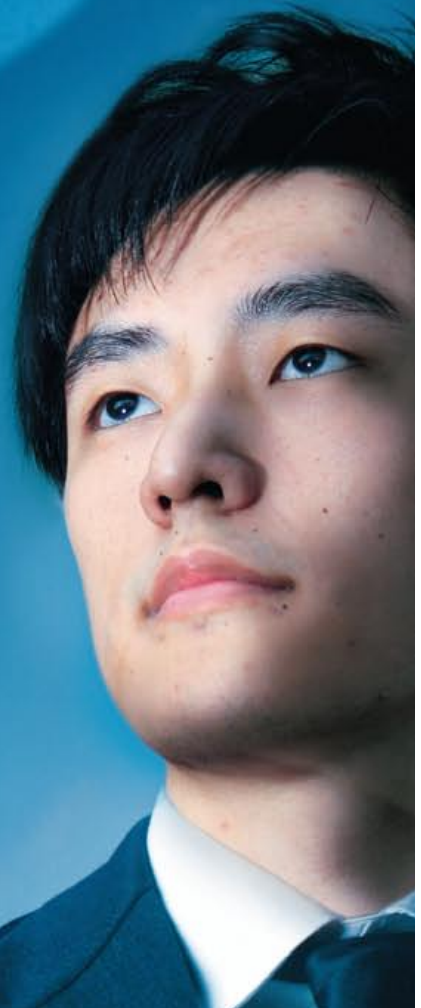

ChangAn Automotive used
dSPACE tools to develop hybrid
control functions in their new
Jiexun mild hybrid car



Lower emissions and more fuel economy: the Jiexun mild hybrid.

Hardware-in-the-loop testing at ChangAn Automotive.



The new ChangAn Jiexun mild hybrid car successfully rolled off the production line in December 2008 – containing a comprehensive hybrid controller strategy developed with dSPACE tools. During the 2008 Beijing Olympic Games, ChangAn already provided several pre-production hybrid Jiexuns as taxis and a press fleet. About 80% of the hybrid controller strategy's code was generated with dSPACE TargetLink. ChangAn also used dSPACE Micro-AutoBoxes and dSPACE Simulator for successful controller development and testing.

Reducing Emissions and Saving Fuel

Following the Chinese market's needs for lower-emission and more fuel-economic passenger cars, ChangAn launched the "Jiexun" (杰勋: hero + glorious deed; pronounced: jié xūn [dʒiɛ ɕyn]) hybrid project in late 2005, working closely together with several cooperating partners. As a mild hybrid car, the Jiexun offers features such as electric engine based parking (while the gasoline engine is in idling mode), power assistance and regenerative braking. Unlike full hybrid cars, the current Jiexun hybrid version does not offer autonomous electric driving yet. However, a full hybrid version with autonomous gasoline and electric engines is under development and will soon be introduced onto the Chinese market.

The fuel consumption of the current mild hybrid Jiexun averages 6.8 l/100 km or 34.6 miles per gallon (city traffic and expressway combined), and the emissions meet the Euro IV standard, which is in the process of becoming a standard in the P. R. China. During the 2008 Beijing Olympic Games, the Jiexun helped make the idea of a green, high-tech Olympics a reality. In Beijing, some 25 pre-production mild hybrid Jiexuns served as taxis and a press fleet during the games. ChangAn also

provided 1,000 mild hybrid Jiexuns to the City of Chongqing and became the city's official partner for the Olympic project "1,000 vehicles for each 10 cities", which was initiated to demonstrate green technologies to a wide audience.

Developing New Control Units

The development project for the ChangAn Jiexun mild hybrid car consisted of three major phases of development with the respective outputs A, B and C sample (a func-

"We developed the new control algorithms of the Jiexun mild hybrid control strategy with TargetLink. 80% of the code was generated automatically by TargetLink."

Dr. Ling Su, ChangAn Automotive

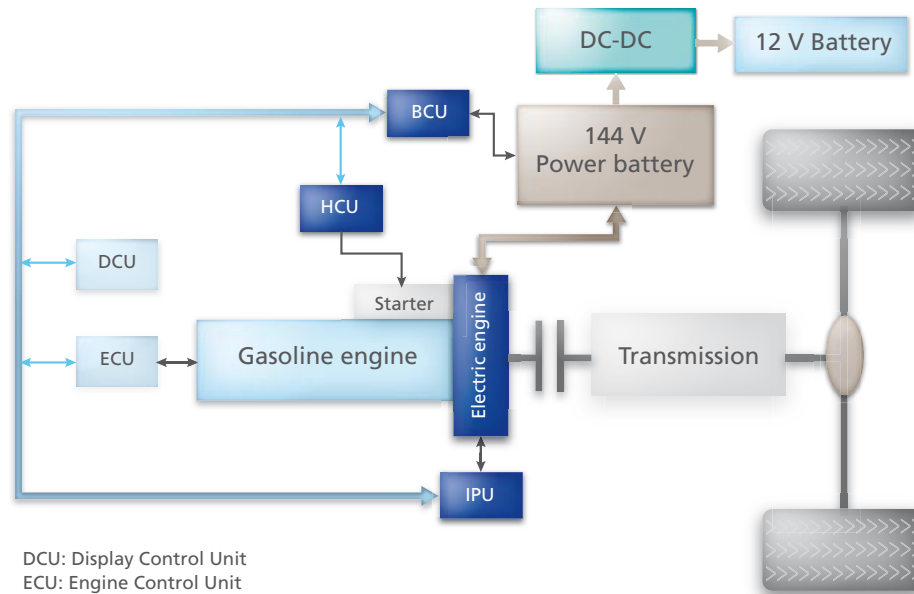

The hybrid powertrain system of ChangAn's hybrid car contains three newly developed control units: the hybrid control unit (HCU), the battery control unit (BCU), and an intelligent power unit (IPU).

tional sample vehicle, a performance sample vehicle, and an end-product sample vehicle). The project focused especially on the multi-energies management system, the battery system technology, and the electric engine technology. ChangAn developed a new hybrid control unit (HCU) as the superordinate con-

generations, and to master the new technologies by themselves. An efficient, application-tailored tool chain is a key requirement for such tasks. ChangAn relied on the dSPACE tool chain during the entire development process, and will continue to use dSPACE tools in future high-demand projects.

the battery pack is 144 V. It is connected on the one hand to the electric engine and on the other via a DC-DC converter to the car's 12 V onboard power supply, which in turn is backed by a 12 V battery. The battery management for both batteries is implemented on the BCU. The HCU acts as a superordinate controller.

“Compared to competitors’ code generators, ChangAn found the TargetLink-generated code to be of higher quality and efficiency.”

Dr. Ling Su, ChangAn Automotive

troller, as well as a battery control unit (BCU) and an intelligent power unit (IPU).

The Jiexun was one of the first hybrid cars developed in China. The hybrid components that are used are also brand-new. ChangAn developed most parts of the new control units necessary for a hybrid vehicle by themselves (with assistance from engineering partners) instead of buying units from suppliers, because their major goal was to establish an autonomous development and production chain for hybrid cars for future Chinese car

Jiexun's Hybrid Electrical System

To create a mild hybrid, ChangAn integrated an electric engine into the Jiexun, in addition to a gasoline engine. The electric engine is controlled via the IPU, which also contains strategies for coupling the electric engine and the gasoline engine, such as torque distribution in different situations. The power for the electric engine is supplied by a dedicated battery pack. ChangAn uses a nickel-metal hydride battery pack, allowing a maximum voltage of 200 V and a maximum current of ± 200 A. The operating output of

Development Process and Development Tool Chain

To develop and test the controller software and the control units, ChangAn relied on a model-based design process from beginning to end. The software for the new vehicle controllers was developed from scratch, following typical steps such as function design, rapid prototyping, ECU autocoding, hardware-in-the-loop (HIL) testing and ECU calibration. The control functions were designed in MATLAB®/ Simulink®. To develop and test the control strategy on in-vehicle tests, and to generate test signals during the platform reliability tests, ChangAn intensively used the dSPACE MicroAutoBox, in combination with peripheral circuits for sensor and actuator connection. To verify the function strategy and test the CAN-based communication and the



“To develop the controllers of the new Jiexun hybrid vehicle, we relied on a dSPACE tool chain during the whole development process, and we will continue to use the dSPACE tools for further demanding projects.”

Dr. Ling Su, ChangAn Automotive

software logic, ChangAn employed dSPACE Simulator, with dSPACE ControlDesk as the experiment software. The simulation models were partly in-house from ChangAn, and partly provided by an engineering partner. The test automation was done by an engineering partner, using dSPACE AutomationDesk. For measurement and calibration tasks, ChangAn used dSPACE CalDesk plus a further calibration tool. This seamless tool chain helped achieve the development goals on time.

From Function Design to ECU Software

To develop software for the performance sample vehicle, TargetLink served as the main development tool and for automatic C code generation from Simulink blocks. Model-in-the-loop (MIL) testing was intensively used to test the sub-modules of the controller model. MIL testing as a “front loading” activity brought ChangAn valuable quality improvements and saved time in the subsequent process steps. Via software-in-the-loop (SIL) testing, ChangAn compared the behavior of the generated code with the MIL testing results. Finally, ChangAn prepared the code for the S12XDP512 microcontroller

with the help of processor-in-the-loop (PIL) simulation. TargetLink’s comprehensive simulation techniques were a highly effective accelerator for the project.

Comprehensive HIL Tests

To test the HCU, the ECU, the IPU and the BCU simultaneously and automatically, ChangAn used dSPACE Simulator again. Numerous test cases were run. For example, ChangAn simulated the overall network behavior in the case of sudden voltage changes, and simulated failure events in the CAN communication network. Once again, the test automation was done by an engineering partner, using AutomationDesk. The final calibration was done with CalDesk plus a further calibration tool. ■

*Dr. Ling Su
ChangAn Automotive
P. R. China*

Conclusion and Outlook

ChangAn aims to master the core technologies in the field of hybrid drives with independent development capabilities, and to formulate a complete development and production process for hybrid cars. The emerging hybrid technologies and their integration into vehicles are a challenge: many software and hardware elements need to be developed from scratch, as there has been no precedent in China so far. dSPACE tools helped the company take an enormous step in hybrid car development. ChangAn has set up a professional research and development team to tackle key technical problems by fully utilizing and integrating resource advantages both at home in China and abroad. ChangAn plans to further apply dSPACE products for the development of electronic control units, hybrid cars, pure electric drives, fuel cell technology, solar energy technology, etc.